



# TECTUL

## UNIÓN RÍGIDA RANURADA

### CARACTERÍSTICAS

### APLICACIONES

### MATERIALES

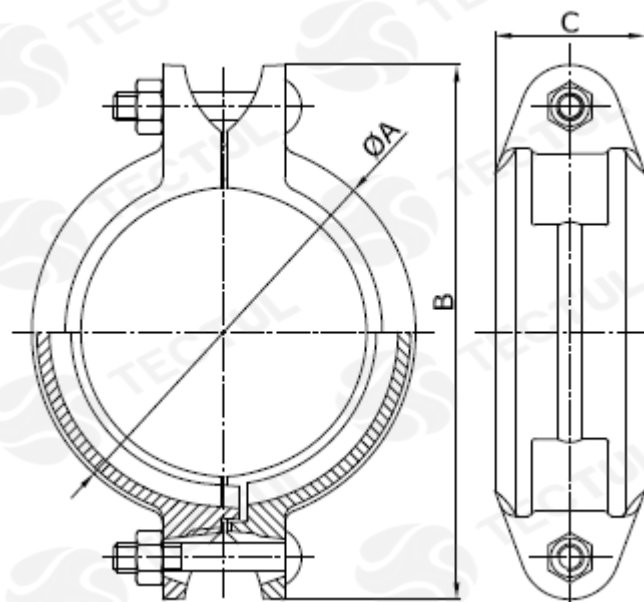

\* Vista de sección transversal de tipo informativa. No representa versión específica en la Unión.

### CARACTERÍSTICAS

Tiene pernos métricos y tuercas hexagonales reforzadas.  
Ajustable a tubería estándar  
Presiones de trabajo hasta 500 PSI.

### MATERIALES

Fundición de hierro dúctil conforme ASTM a-536. Grado 65-45-12.

### APLICACIONES

Ideales para redes contraincendios.

### DATOS TÉCNICOS

MEDIDA	DIAMETRO EXTERIOR EN TUBERÍA [mm]	DIAMETRO UNIÓN RÍGIDA [mm] (Ø)	LONGITUD [mm] (B)	ANCHO [mm] (C)	PESO [g]
1"	33,70*	37,00*	102,00*	45,00*	540,00*
1 1/4"	42,40*	41,00*	106,00*	44,00*	560,00*
1 1/2"	48,30*	46,00*	108,00*	44,00*	630,00*
2"	60,30*	55,00*	123,00*	44,00*	680,00*
2 1/2"	76,10*	58,00*	142,00*	45,00*	790,00*
3"	88,90*	62,00*	166,00*	45,00*	1020,00*
4"	114,30*	89,00*	190,00*	49,00*	1400,00*
5"	139,70*	71,00*	218,00*	49,00*	1740,00*
6"	168,30*	80,00*	249,00*	50,00*	2300,00*

\* Fotos y medidas referenciales, sujetas a cambios sin previo aviso por parte del proveedor o fabricante.



# TECTUL

## RIGID GROOVED JOINT

### CARACTERÍSTICAS

### APLICACIONES

### MATERIALES

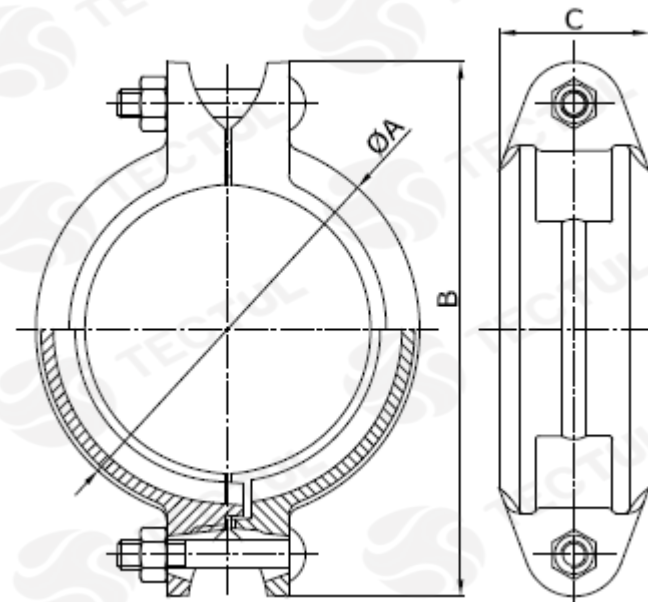

\* Informational type cross section view. It does not represent a specific version on the Joint.

### CHARACTERISTICS

Has metric bolts and nuts reinforced hexes.  
Adjustable to standard pipe  
Working pressures up to 500 PSI.

### MATERIALS

ASTM compliant ductile iron casting  
a-536. Grade 65-45-12.

### APPLICATIONS

Ideal for fire networks.

### TECHNICAL DATA

MEASURE	PIPE EXTERNAL DIAMETER [mm]	RIGID COUPLING DIAMETER [mm] (Ø)	LENGHT [mm] (B)	WIDTH [mm] (C)	WEIGHT [g]
1"	33,70*	37,00*	102,00*	45,00*	540,00*
1 1/4"	42,40*	41,00*	106,00*	44,00*	560,00*
1 1/2"	48,30*	46,00*	108,00*	44,00*	630,00*
2"	60,30*	55,00*	123,00*	44,00*	680,00*
2 1/2"	76,10*	58,00*	142,00*	45,00*	790,00*
3"	88,90*	62,00*	166,00*	45,00*	1020,00*
4"	114,30*	89,00*	190,00*	49,00*	1400,00*
5"	139,70*	71,00*	218,00*	49,00*	1740,00*
6"	168,30*	80,00*	249,00*	50,00*	2300,00*

\* Reference photos and measurements, subject to change without prior notice from the supplier or manufacturer.