



TECTUL

BRIDA SLIP-ON ACERO FORJADO A105 ANSI/ASME B16.5 RF CLASE 150

MATERIALES

CARACTERÍSTICAS FÍSICAS



CARACTERÍSTICAS DIMENSIONALES

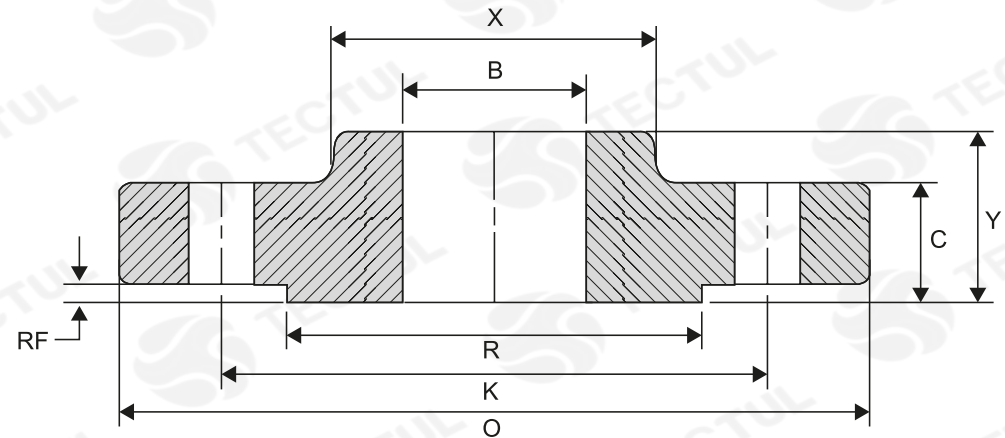

* Vista de sección transversal de tipo informativa. No representa una versión específica del accesorio o elemento.

DATOS TÉCNICOS

MEDIDA NOMINAL	DIÁMETRO EXTERIOR		ESPESOR [mm] (C)	DIÁMETRO EJE-BASE [mm] (X)	DIÁMETRO EJE-AGUJEROS [mm] (K)	LARGO A TRAVÉS DEL EJE [mm] (Y)	CARA REALZADA [RF]	DIÁMETRO CARA REALZADA [mm] (R)	DIÁMETRO AGUJERO [mm] (B)	DIÁMETRO AGUJEROS	NÚMERO AGUJEROS	PESO (kg)	DIÁMETRO DE PERNOS		LARGO DE PERNOS		
	[In]	[mm]											[In]	[mm]	HILO CORRIDO	JUNTA ANILLO	PERNO
		[mm] (O)													2MM CARA REALZADA		2MM CARA REALZADA
1/2"	12	88,90*	11,10*	30,20*	60,40*	15,70*	1,5*	35,00*	22,30*	15,70*	4*	0,47*	1/2"	13,00*	55*	...	50*
3/4"	18	98,50*	12,70*	38,10*	69,80*	15,70*	1,5*	42,90*	27,60*	15,70*	4*	0,59*	1/2"	13,00*	65*	...	50*
1"	25	107,90*	14,20*	49,20*	79,20*	17,50*	1,5*	50,80*	34,50*	15,70*	4*	0,86*	1/2"	13,00*	65*	75*	55*
1-1/4"	31	117,30*	15,70*	58,60*	88,90*	20,50*	1,5*	63,50*	43,10*	15,70*	4*	1,08*	1/2"	13,00*	70*	85*	55*
1-1/2"	38	127,00*	17,50*	65,00*	98,50*	22,30*	1,5*	73,10*	49,50*	15,70*	4*	1,41*	1/2"	13,00*	70*	85*	65*
2"	50	152,40*	19,00*	77,70*	120,60*	25,40*	1,5*	91,90*	61,90*	19,00*	4*	2,26*	5/8"	16,00*	85*	95*	70*
2-1/2"	63	177,80*	22,30*	90,40*	139,70*	28,40*	1,5*	104,60*	74,60*	19,00*	4*	3,43*	5/8"	16,00*	90*	100*	75*
3"	75	190,50*	23,80*	107,90*	152,40*	30,20*	1,5*	127,00*	90,60*	19,00*	4*	3,87*	5/8"	16,00*	90*	100*	75*
4"	100	228,60*	23,80*	134,80*	190,50*	33,20*	1,5*	157,20*	116,00*	19,00*	8*	5,75*	5/8"	16,00*	90*	100*	75*
5"	125	254,00*	23,80*	163,50*	215,90*	36,50*	1,5*	185,60*	143,70*	22,30*	8*	6,22*	3/4"	19,00*	95*	110*	85*
6"	150	279,40*	25,40*	192,00*	241,30*	39,60*	1,5*	215,90*	170,60*	22,30*	8*	7,38*	3/4"	19,00*	100*	115*	85*
8"	200	342,90*	28,40*	246,10*	298,40*	44,40*	1,5*	269,70*	221,40*	22,30*	8*	12,36*	3/4"	19,00*	110*	120*	90*
10"	250	406,40*	30,20*	304,80*	361,90*	49,20*	1,5*	323,80*	276,30*	25,40*	12*	17,10*	7/8"	22,50*	115*	125*	100*
12"	300	482,60*	31,70*	365,20*	431,80*	55,60*	1,5*	381,00*	327,10*	25,40*	12*	27,68*	7/8"	22,50*	120*	135*	100*
14"	350	533,40*	35,00*	400,00*	476,20*	57,10*	1,5*	412,70*	359,10*	28,40*	12*	35,20*	1"	25,50*	135*	145*	115*
16"	400	596,90*	36,50*	457,20*	539,70*	63,50*	1,5*	469,90*	410,40*	28,40*	16*	42,18*	1"	25,50*	135*	145*	115*
18"	450	635,00*	39,60*	504,90*	577,80*	68,30*	1,5*	533,40*	461,70*	31,70*	16*	49,71*	1-1/8"	28,50*	145*	160*	125*
20"	500	698,50*	42,90*	558,80*	635,00*	73,10*	1,5*	584,20*	513,00*	31,70*	20*	65,50*	1-1/8"	28,50*	160*	170*	140*
24"	600	812,80*	47,70*	663,40*	749,30*	82,50*	1,5*	692,10*	615,90*	35,00*	20*	90,50*	1-1/4"	32,00*	170*	185*	150*

* Fotos y medidas referenciales, sujetas a cambios sin previo aviso por parte del proveedor o fabricante.



TECTUL

SLIP-ON FLANGE FORGED STEEL A105 ANSI/ASME B16.5 RF CLASS 150

MATERIALS

PHYSICAL CHARACTERISTICS



DIMENSIONAL CHARACTERISTICS

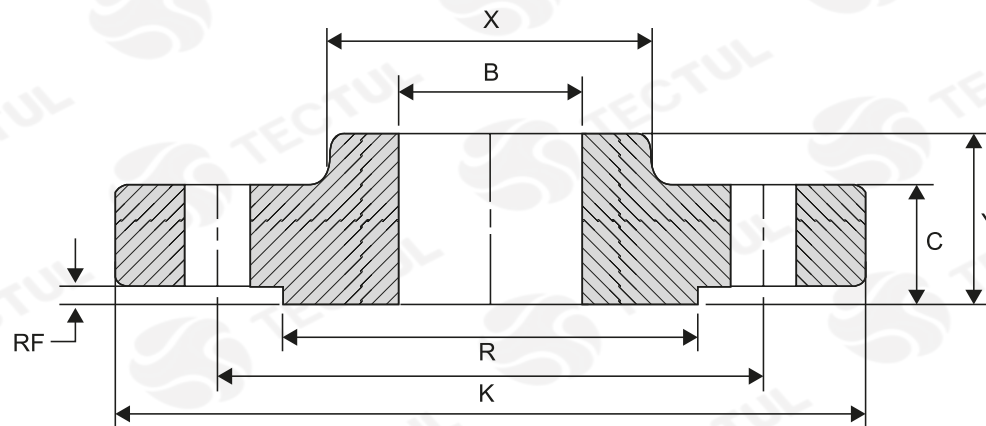

* Informational cross-sectional view. Does not represent a specific version of the accessory or item.

TECHNICAL DATA

NOMINAL SIZE	OUTSIDE DIAMETER	THICKNESS	SHAFT-BASE DIAMETER	SHAFT-HOLES DIAMETER	LENGTH THROUGH AXIS	RAISED FACE [RF]	RAISED FACE DIAMETER	HOLE DIAMETER	DIAMETER OF HOLES	NUMBER OF HOLES	WEIGHT (kg)	LENGTH OF BOLTS					
												BOLTS DIAMETER	RUNNING THREAD	RING JOINT	BOLT		
[In] [mm]	[mm] (O)	[mm] (C)	[mm] (X)	[mm] (K)	[mm] (Y)		[mm] (R)	[mm] (B)				[In] [mm]	2MM RAISED FACE		2MM RAISED FACE		
1/2"	12	88,90*	11,10*	30,20*	60,40*	15,70*	1,5*	35,00*	22,30*	15,70*	4*	0,47*	1/2"	13,00*	55*	...	50*
3/4"	18	98,50*	12,70*	38,10*	69,80*	15,70*	1,5*	42,90*	27,60*	15,70*	4*	0,59*	1/2"	13,00*	65*	...	50*
1"	25	107,90*	14,20*	49,20*	79,20*	17,50*	1,5*	50,80*	34,50*	15,70*	4*	0,86*	1/2"	13,00*	65*	75*	55*
1-1/4"	31	117,30*	15,70*	58,60*	88,90*	20,50*	1,5*	63,50*	43,10*	15,70*	4*	1,08*	1/2"	13,00*	70*	85*	55*
1-1/2"	38	127,00*	17,50*	65,00*	98,50*	22,30*	1,5*	73,10*	49,50*	15,70*	4*	1,41*	1/2"	13,00*	70*	85*	65*
2"	50	152,40*	19,00*	77,70*	120,60*	25,40*	1,5*	91,90*	61,90*	19,00*	4*	2,26*	5/8"	16,00*	85*	95*	70*
2-1/2"	63	177,80*	22,30*	90,40*	139,70*	28,40*	1,5*	104,60*	74,60*	19,00*	4*	3,43*	5/8"	16,00*	90*	100*	75*
3"	75	190,50*	23,80*	107,90*	152,40*	30,20*	1,5*	127,00*	90,60*	19,00*	4*	3,87*	5/8"	16,00*	90*	100*	75*
4"	100	228,60*	23,80*	134,80*	190,50*	33,20*	1,5*	157,20*	116,00*	19,00*	8*	5,75*	5/8"	16,00*	90*	100*	75*
5"	125	254,00*	23,80*	163,50*	215,90*	36,50*	1,5*	185,60*	143,70*	22,30*	8*	6,22*	3/4"	19,00*	95*	110*	85*
6"	150	279,40*	25,40*	192,00*	241,30*	39,60*	1,5*	215,90*	170,60*	22,30*	8*	7,38*	3/4"	19,00*	100*	115*	85*
8"	200	342,90*	28,40*	246,10*	298,40*	44,40*	1,5*	269,70*	221,40*	22,30*	8*	12,36*	3/4"	19,00*	110*	120*	90*
10"	250	406,40*	30,20*	304,80*	361,90*	49,20*	1,5*	323,80*	276,30*	25,40*	12*	17,10*	7/8"	22,50*	115*	125*	100*
12"	300	482,60*	31,70*	365,20*	431,80*	55,60*	1,5*	381,00*	327,10*	25,40*	12*	27,68*	7/8"	22,50*	120*	135*	100*
14"	350	533,40*	35,00*	400,00*	476,20*	57,10*	1,5*	412,70*	359,10*	28,40*	12*	35,20*	1"	25,50*	135*	145*	115*
16"	400	596,90*	36,50*	457,20*	539,70*	63,50*	1,5*	469,90*	410,40*	28,40*	16*	42,18*	1"	25,50*	135*	145*	115*
18"	450	635,00*	39,60*	504,90*	577,80*	68,30*	1,5*	533,40*	461,70*	31,70*	16*	49,71*	1-1/8"	28,50*	145*	160*	125*
20"	500	698,50*	42,90*	558,80*	635,00*	73,10*	1,5*	584,20*	513,00*	31,70*	20*	65,50*	1-1/8"	28,50*	160*	170*	140*
24"	600	812,80*	47,70*	663,40*	749,30*	82,50*	1,5*	692,10*	615,90*	35,00*	20*	90,50*	1-1/4"	32,00*	170*	185*	150*

* Reference photos and measurements, subject to change without prior notice from the supplier or manufacturer.