



TECTUL

POLEA CON BASE 2" PERFIL EN V CON RODAMIENTO

MATERIALES

CARACTERÍSTICAS FÍSICAS



CARACTERÍSTICAS DIMENSIONALES



CARACTERÍSTICAS

Diseñada para aumentar la fuerza de elevación con una rueda de seguimiento y un cable, cuerda o cadena.

MATERIALES

Acero al carbono laminado en frío según normas AISI/SAE 1045, DIN C22 o UNS G 10200.

APLICACIONES

Diseñadas para el sector agrícola. Ideales para el secado de café, cacao, maíz y para el transporte e izado de carga.

DATOS TÉCNICOS

COMPONENTES	CARGA ESTÁTICA
Base en Acero A36	200 kg
Disco en Acero SAE/1045	
Tuerca De Seguridad M10	
Tornillo M10 X 40mm Galvanizado	
Arandela M10	
Rodamiento Rígido de Bolas 6000	

* Fotos y medidas referenciales, sujetas a cambios sin previo aviso por parte del proveedor o fabricante.

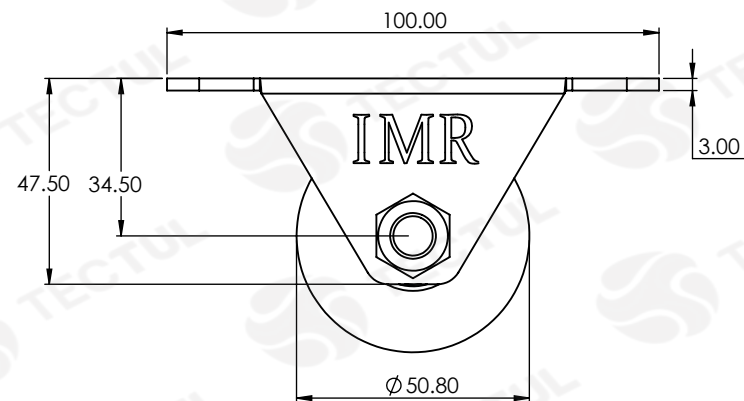
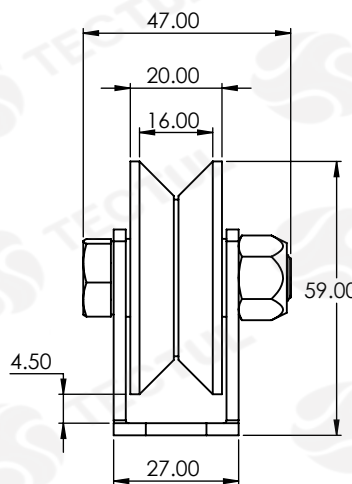

* Vista de sección transversal de tipo informativa. No representa una versión específica del accesorio o elemento
Las tolerancias pueden variar ± 2 mm

* Fotos y medidas referenciales, sujetas a cambios sin previo aviso por parte del proveedor o fabricante.



TECTUL

PULLEY WITH BASE 2" PROFILE V WITH BEARINGS

MATERIALS

PHYSICAL CHARACTERISTICS

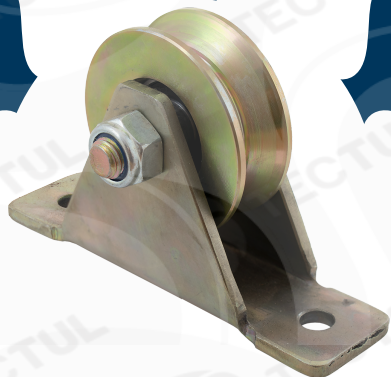

DIMENSIONAL CHARACTERISTICS



TECHNICAL DATA	
COMPONENTS	STATIC LOAD
A36 Steel Base	200 kg
SAE/1045 Steel Disc	
M10 Lock Nut	
Screw M10 X 40 mm Galvanized	
Washer M10	
Ball Bearing 6000	

* Reference photos and measurements, subject to change without prior notice from the supplier or manufacturer.

CHARACTERISTICS
 Designed to increase the strength of lifting with a wheel track and a cable, rope or chain.

MATERIALS
 Cold rolled carbon steel according to standards AISI/SAE 1045, DIN C22 or UNS G 10200.

APPLICATIONS
 Designed for the agricultural sector. Ideals for drying coee, cocoa, corn and for the transport and lifting of loads.

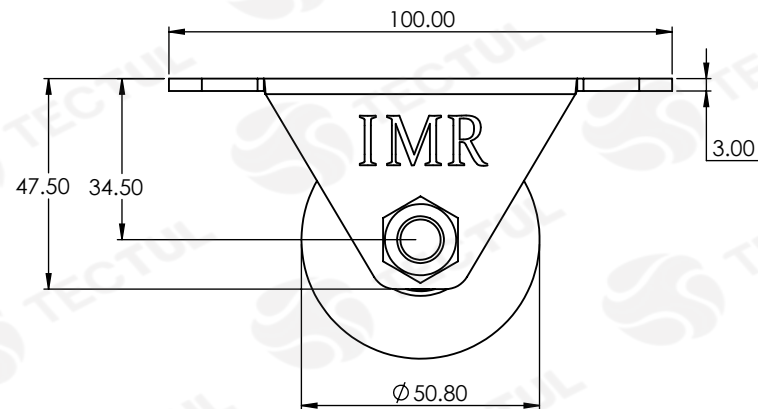
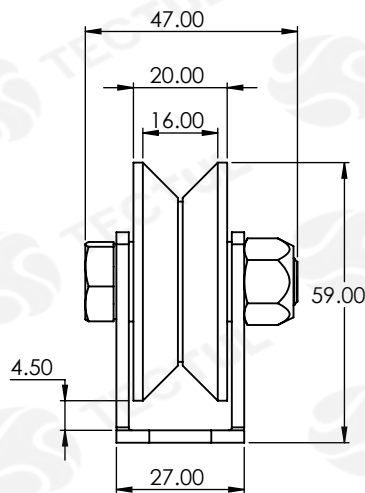

* Informational type cross section view. Does not represent a specific version of the accessory or item. Tolerances can vary ± 2mm

* Reference photos and measurements, subject to change without prior notice from the supplier or manufacturer.