



TECTUL

POLEA CON BASE 2-1/2" PERFIL EN V SIN RODAMIENTO

MATERIALES

CARACTERÍSTICAS FÍSICAS



CARACTERÍSTICAS DIMENSIONALES



DATOS TÉCNICOS	
COMPONENTES	CARGA ESTÁTICA
Base en Acero A36	200 kg
Disco en Acero SAE/1045	
Tuerca De Seguridad M12	
Tornillo M12 X 40mm Galvanizado	
Arandela M12	
Buje 3/8" x 7.8mm	

* Fotos y medidas referenciales, sujetas a cambios sin previo aviso por parte del proveedor o fabricante.

CARACTERÍSTICAS



Diseñada para aumentar la fuerza de elevación con una rueda de seguimiento y un cable, cuerda o cadena.

MATERIALES



Acero al carbono laminado en frío según normas AISI/SAE 1045, DIN C22 o UNS G 10200.

APLICACIONES



Diseñadas para el sector agrícola. Ideales para el secado de café, cacao, maíz y para el transporte e izado de carga.

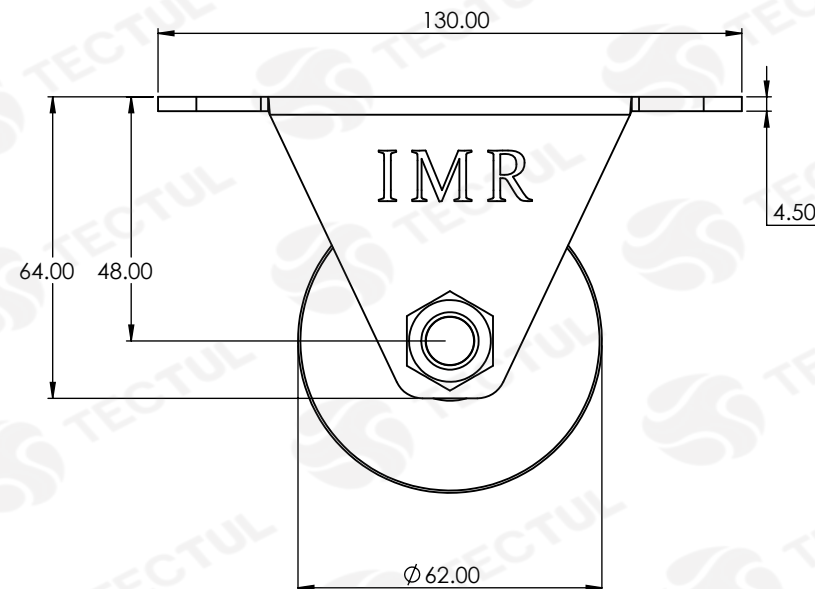
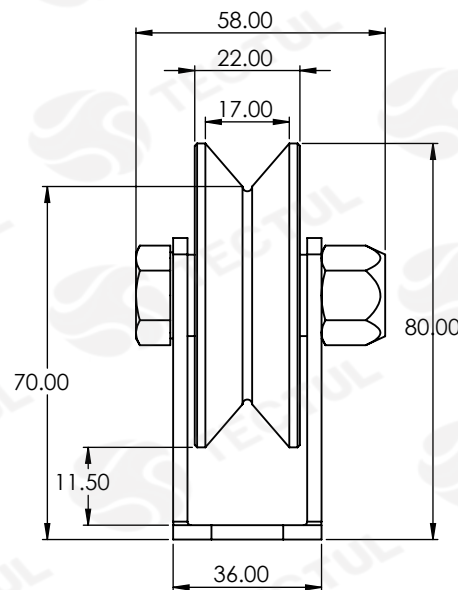

* Fotos y medidas referenciales, sujetas a cambios sin previo aviso por parte del proveedor o fabricante.

* Vista de sección transversal de tipo informativa. No representa una versión específica del accesorio o elemento
Las tolerancias pueden variar ± 2 mm



TECTUL

PULLEY WITH BASE 2-1/2" PROFILE V

MATERIALS

PHYSICAL CHARACTERISTICS



DIMENSIONAL CHARACTERISTICS



TECHNICAL DATA	
COMPONENTS	STATIC LOAD
A36 Steel Base	200 kg
SAE/1045 Steel Disc	
M12 Lock Nut	
Screw M12 X 40 mm Galvanized	
Washer M12	
Bushing 3/8" x 7.8 mm	

* Reference photos and measurements, subject to change without prior notice from the supplier or manufacturer.

CHARACTERISTICS
 Designed to increase the strength of lifting with a wheel track and a cable, rope or chain.

MATERIALS
 Cold rolled carbon steel according to standards AISI/SAE 1045, DIN C22 or UNS G 10200.

APPLICATIONS
 Designed for the agricultural sector. Ideals for drying coee, cocoa, corn and for the transport and lifting of loads.

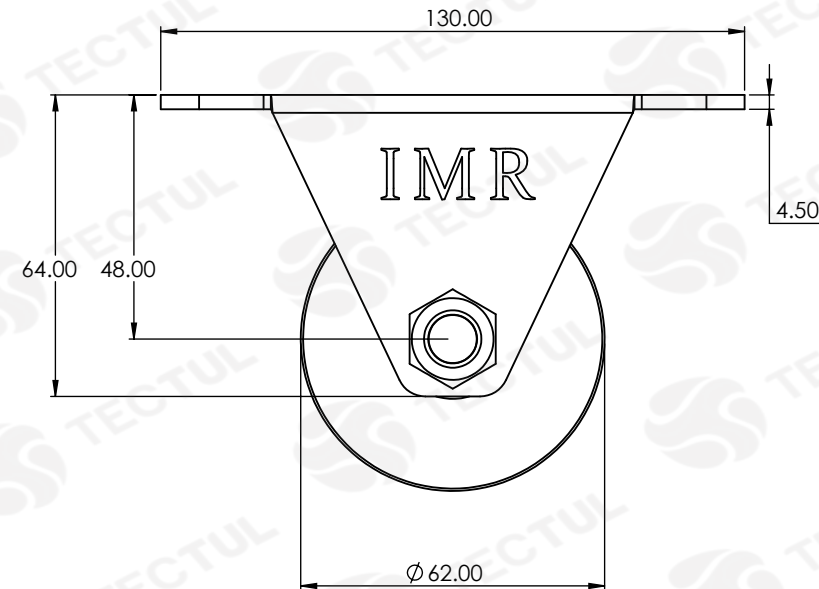
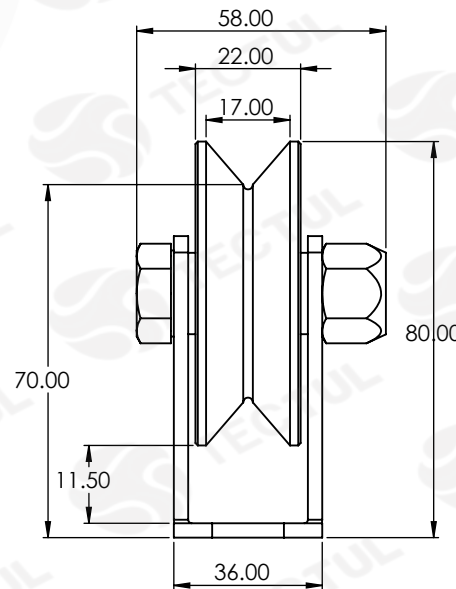

* Informational type cross section view. Does not represent a specific version of the accessory or itemTolerances can vary ± 2mm

* Reference photos and measurements, subject to change without prior notice from the supplier or manufacturer.