



TECTUL

POLEA SIN BASE 1-1/2" PERFIL V SIN RODAMIENTO

MATERIALES

CARACTERÍSTICAS FÍSICAS



CARACTERÍSTICAS DIMENSIONALES

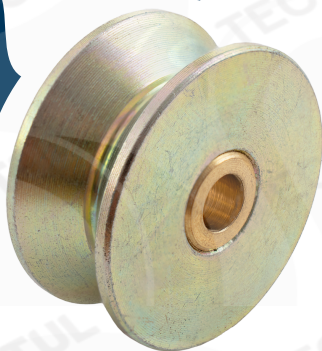
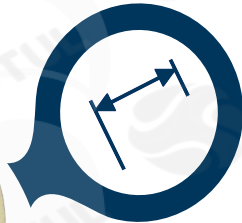

CARACTERÍSTICAS

Diseñada para aumentar la fuerza de elevación con una rueda de seguimiento y un cable, cuerda o cadena.

MATERIALES

Acero al carbono laminado en frío según normas AISI/SAE 1045, DIN C22 o UNS G 10200.

APLICACIONES

Diseñadas para el sector agrícola. Ideales para el secado de café, cacao, maíz y para el transporte e izado de carga.

DATOS TÉCNICOS

COMPONENTES	CARGA ESTÁTICA
Disco en Acero SAE/1045	100 kg
Tuerca De Seguridad M7	
Tornillo M7 X 35 mm Galvanizado	
Buje Bronce Latón 1/2"	

* Fotos y medidas referenciales, sujetas a cambios sin previo aviso por parte del proveedor o fabricante.

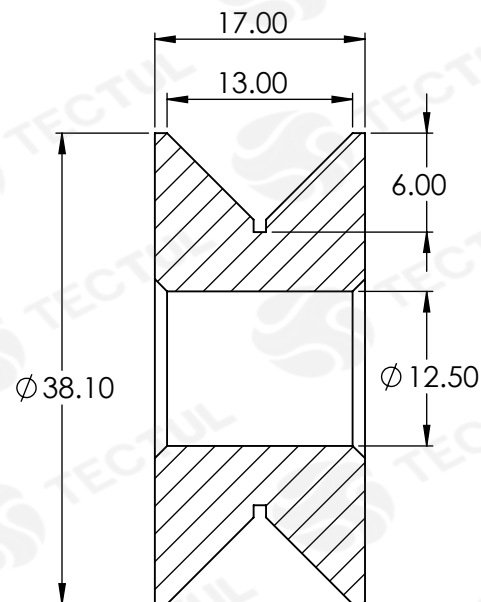

* Vista de sección transversal de tipo informativa. No representa una versión específica del accesorio o elemento
Las tolerancias pueden variar $\pm 2\text{mm}$

* Fotos y medidas referenciales, sujetas a cambios sin previo aviso por parte del proveedor o fabricante.



TECTUL

PULLEY WITHOUT BASE 1-1/2" PROFILE V WITHOUT BEARINGS

MATERIALS

PHYSICAL CHARACTERISTICS

DIMENSIONAL CHARACTERISTICS

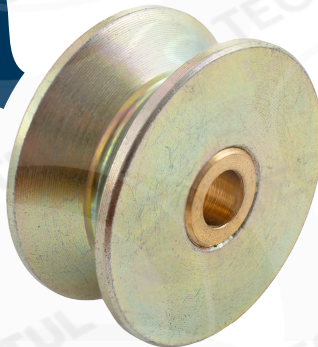

TECHNICAL DATA	
COMPONENTS	STATIC LOAD
SAE/1045 Steel Disc	100 kg
M7 Lock Nut	
Screw M7 X 35 mm Galvanized	
1/2" Brass Bronze Bushing	

* Reference photos and measurements, subject to change without prior notice from the supplier or manufacturer.

CHARACTERISTICS

Designed to increase the strength of lifting with a wheel track and a cable, rope or chain.

MATERIALS

Cold rolled carbon steel according to standards AISI/SAE 1045, DIN C22 or UNS G 10200.

APPLICATIONS

Designed for the agricultural sector. Ideals for drying coee, cocoa, corn and for the transport and lifting of loads.

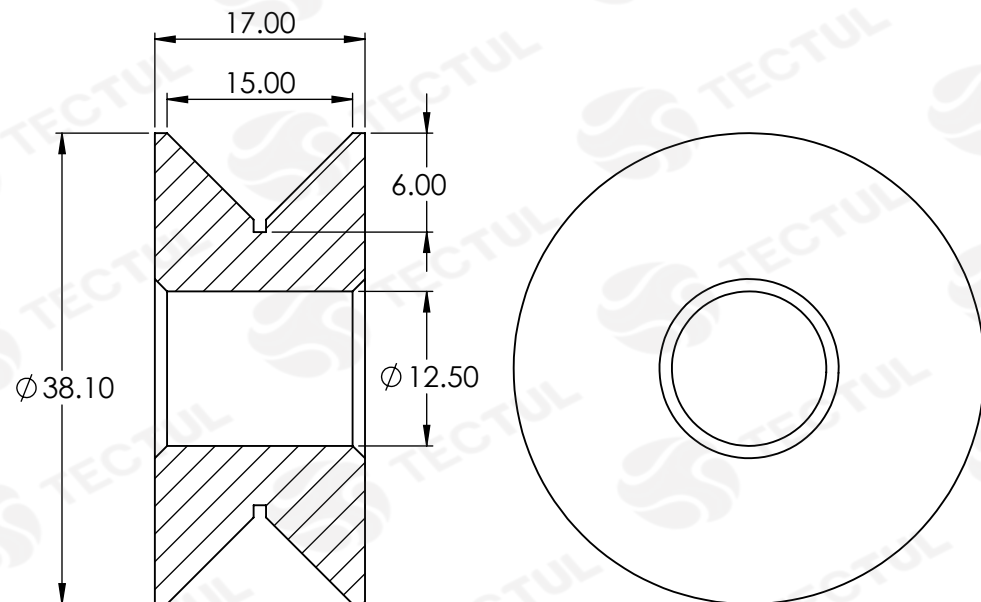

* Informational type cross section view. Does not represent a specific version of the accessory or item. Tolerances can vary ± 2 mm

* Reference photos and measurements, subject to change without prior notice from the supplier or manufacturer.