



TECTUL

ABRAZADERA INDUSTRIAL

MATERIALES

CARACTERÍSTICAS FÍSICAS



CARACTERÍSTICAS DIMENSIONALES

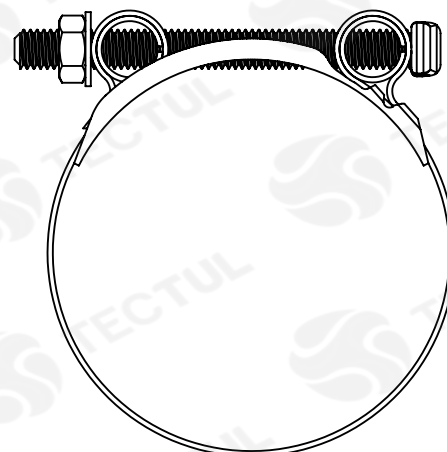
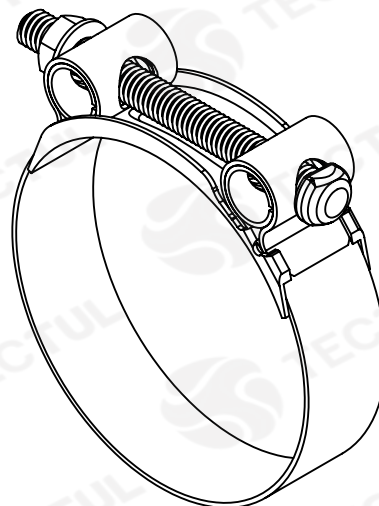

MATERIALES

Fabricado en hierro maleable galvanizado
Recubierto ASTM A-197
ASTM A153 HOT-DIP (Caliente)



CARACTERÍSTICAS FÍSICAS

Cumple con los estándares de diseño
ANSI / ASME B16.3 y B16.14,
Extremos reforzados y estándar UL / FM



CARACTERÍSTICAS DIMENSIONALES

Dimensiones básicas según la Norma
Nacional estadounidense. Con conexión
roscada NPT según ANSI / ASME B1.20.1

DATOS TÉCNICOS

REFERENCIA	DIÁMETRO MANGUERA [in]	RANGO [mm]
501	3/4"	28 - 30
502	1"	31 - 33
503	1"	34 - 36
504	1"	36 - 40
505	1 1/4"	40 - 44
506	1 1/4"	44 - 48
507	1 1/2"	48 - 52
508	1 1/2"	52 - 57
509	2"	57 - 62
510	2"	62 - 67
511	2"	67 - 72
512	2 1/2"	72 - 78
513	2 1/2"	78 - 84
514	2 1/2"	84 - 90
515	3"	90 - 96
516	3"	96 - 102
517	3"	102 - 108
518	3"	108 - 114
519	4"	114 - 120
520	4"	120 - 128
521	4"	128 - 136
522	4"	136 - 144
523	4"	144 - 154
524	4"	154 - 164
525	6"	164 - 174
526	6"	174 - 184

* Fotos y medidas referenciales, sujetas a cambios sin previo aviso por parte del proveedor o fabricante.



TECTUL

INDUSTRIAL CLAMP

MATERIALS

PHYSICAL CHARACTERISTICS

DIMENSIONAL CHARACTERISTICS

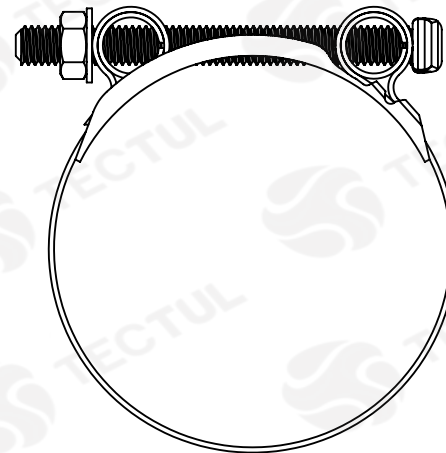
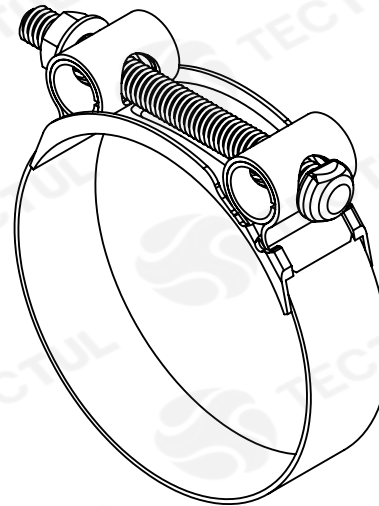

MATERIALS

Made of galvanized malleable iron
ASTM A-197 coated
ASTM A153 HOT-DIP (Hot)



PHYSICAL CHARACTERISTICS

Meet design standards
ANSI / ASME B16.3 and B16.14,
UL / FM standard and reinforced ends



DIMENSIONAL CHARACTERISTICS

Basic dimensions according to the Standard
National American. With threaded connection
NPT per ANSI / ASME B1.20.1

DATOS TÉCNICOS

REFERENCIA	DIÁMETRO MANGUERA [in]	RANGO [mm]
501	3/4"	28 - 30
502	1"	31 - 33
503	1"	34 - 36
504	1"	36 - 40
505	1 1/4"	40 - 44
506	1 1/4"	44 - 48
507	1 1/2"	48 - 52
508	1 1/2"	52 - 57
509	2"	57 - 62
510	2"	62 - 67
511	2"	67 - 72
512	2 1/2"	72 - 78
513	2 1/2"	78 - 84
514	2 1/2"	84 - 90
515	3"	90 - 96
516	3"	96 - 102
517	3"	102 - 108
518	3"	108 - 114
519	4"	114 - 120
520	4"	120 - 128
521	4"	128 - 136
522	4"	136 - 144
523	4"	144 - 154
524	4"	154 - 164
525	6"	164 - 174
526	6"	174 - 184

* Reference photos and measurements, subject to change without prior notice from the supplier or manufacturer.