



TECTUL

REDUCCIÓN CAMPANA INOXIDANTE CLASE 150

MATERIALES

CARACTERÍSTICAS FÍSICAS



CARACTERÍSTICAS DIMENSIONALES

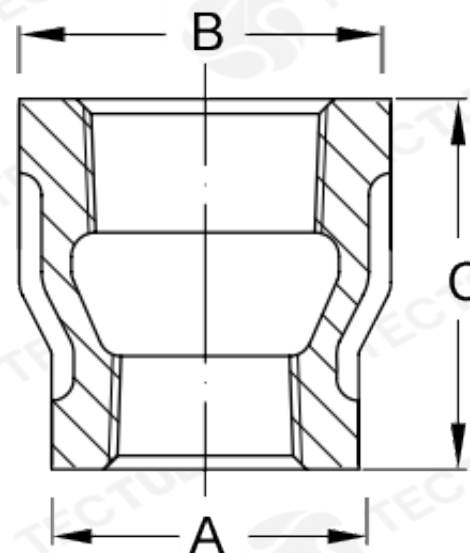

* Vista de sección transversal de tipo informativa. No representa una versión específica del accesorio o elemento.

DATOS TÉCNICOS

MEDIDA	DIAMETRO EXTERIOR 1 [mm] (A)	DIAMETRO EXTERIOR 2 [mm] (B)	ALTURA [mm] (C)	PESO [g]	MEDIDA	DIAMETRO EXTERIOR 1 [mm] (A)	DIAMETRO EXTERIOR 2 [mm] (B)	ALTURA [mm] (C)	PESO [g]
3/8"x 1/4"	20,06*	25,40*	40,89*	24*	2"x 1 1/2"	59,94*	73,91*	67,05*	400*
1/2"x 1/4"	20,06*	29,97*	44,95*	46*	2 1/2" x 1/2"	30,48*	89,91*	75,94*	510*
1/2"x 3/8"	25,40*	29,97*	44,95*	68*	2 1/2"x 3/4"	36,06*	89,91*	75,94*	650*
3/4"x 3/8"	25,40*	36,06*	44,95*	67*	2 1/2"x 1"	44,95*	89,91*	75,94*	720*
3/4"x 1/2"	29,97*	36,06*	44,95*	103*	2 1/2"x 1 1/4"	53,08*	89,91*	75,94*	732*
1"x 1/2"	29,97*	44,95*	50,03*	154*	2 1/2"x 1 1/2"	59,94*	89,91*	75,94*	904*
1"x 3/4"	36,06*	44,95*	50,03*	123*	2 1/2"x 2"	73,91*	89,91*	75,94*	1100*
1 1/4"x 1/2"	29,97*	53,08*	50,03*	173*	3"x 1"	44,95*	108,96*	84,07*	1305*
1 1/4"x 3/4"	36,06*	53,08*	50,03*	173*	3"x 1 1/4"	53,08*	108,96*	84,07*	1431*
1 1/4"x 1"	44,95*	53,08*	50,03*	258*	3"x 1 1/2"	59,94*	108,96*	85,09*	1400*
1 1/2"x 1/2"	29,97*	59,94*	56,89*	220*	3"x 2"	73,91*	108,96*	84,07*	1520*
1 1/2"x 3/4"	36,06*	59,94*	56,89*	221*	3"x 2 1/2"	89,91*	108,96*	83,05*	1608*
1 1/2"x 1"	44,95*	59,94*	56,89*	298*	4"x 1"	44,95*	137,92*	97,02*	2090*
1 1/2"x 1 1/4"	53,08*	59,94*	56,89*	250*	4"x 1 1/4"	53,08*	137,92*	94,99*	2125*
2"x 1/2"	29,97*	73,91*	67,05*	271*	4"x 1 1/2"	59,94*	137,92*	94,99*	2150*
2"x 3/4"	36,06*	73,91*	67,05*	426*	4"x 2"	73,91*	137,92*	97,02*	2206*
2"x 1"	44,95*	73,91*	67,05*	256*	4"x 2 1/2"	89,91*	137,92*	96,01*	2453*
2"x 1 1/4"	53,08*	73,91*	67,05*	307*	4"x 3"	108,96*	137,92*	98,04*	2600*

* Fotos y medidas referenciales, sujetas a cambios sin previo aviso por parte del proveedor o fabricante.

MATERIALES



Fabricados en acero inoxidable
ASTM 351 CF8 (304)

CARACTERÍSTICAS FÍSICAS



Recomendado para la conducción de vapor, gases, ácidos. Uso agroindustrial, procesos de alimentos y azucareras

CARACTERÍSTICAS DIMENSIONALES



Dimensiones básicas según la Norma Nacional estadounidense. Con conexión roscada NPT según ANSI/ASME B1.20.1



TECTUL

STAINLESS REDUCING COUPLING CLASS 150

MATERIALS

PHYSICAL CHARACTERISTICS

DIMENSIONAL CHARACTERISTICS

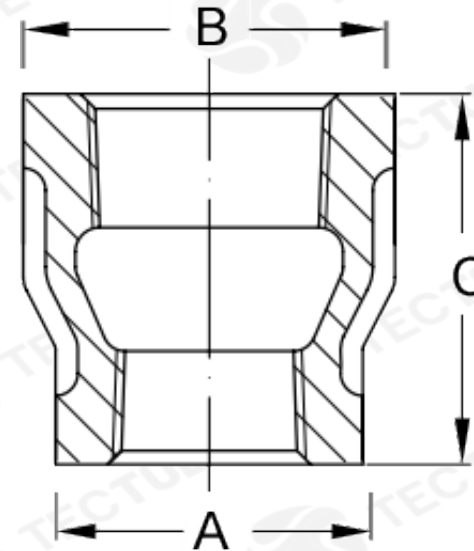

* Informational cross-sectional view. Does not represent a specific version of the accessory or item.

MATERIALS

Made of stainless steel
ASTM 351 CF8 (304)

PHYSICAL CHARACTERISTICS

Recommended for driving steam, gases, acids. Agro-industrial use, food and sugar processing

DIMENSIONAL CHARACTERISTICS

Basic dimensions according to the Standard National American. With threaded connection NPT per ANSI/ASME B1.20.1

TECHNICAL DATA									
MEDIDA	OUTSIDE DIAMETER 1 [mm] (A)	OUTSIDE DIAMETER 2 [mm] (B)	HEIGHT [mm] (C)	WEIGHT [g]	MEDIDA	OUTSIDE DIAMETER 1 [mm] (A)	OUTSIDE DIAMETER 2 [mm] (B)	HEIGHT [mm] (C)	WEIGHT [g]
3/8"x 1/4"	20,06*	25,40*	40,89*	24*	2"x 1 1/2"	59,94*	73,91*	67,05*	400*
1/2"x 1/4"	20,06*	29,97*	44,95*	46*	2 1/2" x 1/2"	30,48*	89,91*	75,94*	510*
1/2"x 3/8"	25,40*	29,97*	44,95*	68*	2 1/2"x 3/4"	36,06*	89,91*	75,94*	650*
3/4"x 3/8"	25,40*	36,06*	44,95*	67*	2 1/2"x 1"	44,95*	89,91*	75,94*	720*
3/4"x 1/2"	29,97*	36,06*	44,95*	103*	2 1/2"x 1 1/4"	53,08*	89,91*	75,94*	732*
1"x 1/2"	29,97*	44,95*	50,03*	154*	2 1/2"x 1 1/2"	59,94*	89,91*	75,94*	904*
1"x 3/4"	36,06*	44,95*	50,03*	123*	2 1/2"x 2"	73,91*	89,91*	75,94*	1100*
1 1/4"x 1/2"	29,97*	53,08*	50,03*	173*	3"x 1"	44,95*	108,96*	84,07*	1305*
1 1/4"x 3/4"	36,06*	53,08*	50,03*	173*	3"x 1 1/4"	53,08*	108,96*	84,07*	1431*
1 1/4"x 1"	44,95*	53,08*	50,03*	258*	3"x 1 1/2"	59,94*	108,96*	85,09*	1400*
1 1/2"x 1/2"	29,97*	59,94*	56,89*	220*	3"x 2"	73,91*	108,96*	84,07*	1520*
1 1/2"x 3/4"	36,06*	59,94*	56,89*	221*	3"x 2 1/2"	89,91*	108,96*	83,05*	1608*
1 1/2"x 1"	44,95*	59,94*	56,89*	298*	4"x 1"	44,95*	137,92*	97,02*	2090*
1 1/2"x 1 1/4"	53,08*	59,94*	56,89*	250*	4"x 1 1/4"	53,08*	137,92*	94,99*	2125*
2"x 1/2"	29,97*	73,91*	67,05*	271*	4"x 1 1/2"	59,94*	137,92*	94,99*	2150*
2"x 3/4"	36,06*	73,91*	67,05*	426*	4"x 2"	73,91*	137,92*	97,02*	2206*
2"x 1"	44,95*	73,91*	67,05*	256*	4"x 2 1/2"	89,91*	137,92*	96,01*	2453*
2"x 1 1/4"	53,08*	73,91*	67,05*	307*	4"x 3"	108,96*	137,92*	98,04*	2600*

* Reference photos and measurements, subject to change without prior notice from the supplier or manufacturer.