



TECTUL

CODO X 90° SCH 80 AC EXTREMOS SOLDABLES

MATERIALES

APLICACIONES

NORMAS DE DISEÑO

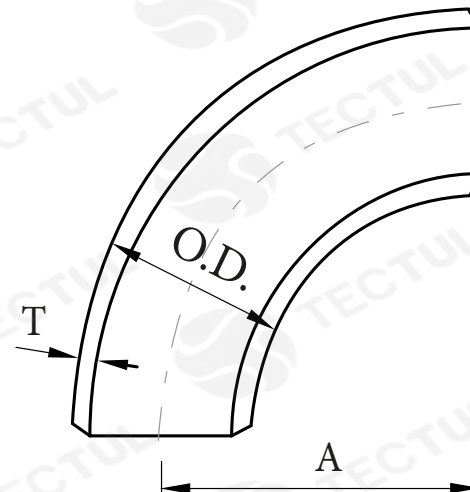

* Vista de sección transversal de tipo informativa. No representa una versión específica del accesorio o elemento.

MATERIALES

Accesorio con conexión soldable Butt Weld, fabricados en acero al Carbono A105 y con extremos biselados. Disponibles en Schedule 40 y 80.

APLICACIONES

Utilizado en instalaciones hidráulicas y transporte de fluidos como agua, aire, vapor, aceites industriales, gases y lubricantes.

NORMAS DE DISEÑO

ANSI / ASME B16.9
ASME B16.28

DATOS TECNICOS

MEDIDA [in]	DIÁMETRO EXTERIOR OD [mm]	ESPESOR T [mm]	CENTRO AL FINAL A [mm]	PESO [Kg]
1/2"	22,3*	3,7*	38,1*	0,1
3/4"	26,7*	3,9*	28,4*	0,14
1"	33,5*	4,5*	38,1*	0,2
1-1/4"	42,2*	4,9*	47,8*	0,35
1-1/2"	48,3*	3,7*	51*	0,5
2"	60,5*	5,5*	76,2*	0,9
2-1/2"	73,2*	7	95,3*	1,79
3"	88,9*	7,6	114,3*	2,74
4"	114,3*	8,6	152,4*	5,36
6"	168,1*	11	228,6*	15

* Fotos y medidas referenciales, sujetas a cambios sin previo aviso por parte del proveedor o fabricante.



TECTUL

ELBOW X 90 ° SCH 80 AC BUTT WELD

MATERIALS



APPLICATIONS



DESIGN STANDARDS

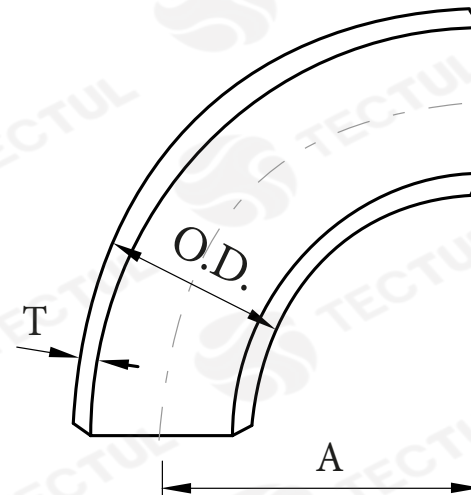

* Informational cross-sectional view. Does not represent a specific version of the accessory or item.



MATERIALS

Butt weldable fitting
Weld, made of carbon steel
A105 and with beveled ends.
Available in Schedule 40 and 80.



APPLICATIONS

Used in hydraulic installations and
transport of fluids such as water, air, steam,
industrial oils, gases and lubricants.



DESIGN STANDARDS

ANSI / ASME B16.9
ASME B16.28

TECHNICAL DATA

MEASURE [in]	EXTERNAL DIAMETER OD [mm]	THICKNESS T [mm]	DISTANCE BETWEEN CENTERS A [mm]	WEIGHT [Kg]
1/2"	22,3*	3,7*	38,1*	0,1
3/4"	26,7*	3,9*	28,4*	0,14
1"	33,5*	4,5*	38,1*	0,2
1-1/4"	42,2*	4,9*	47,8*	0,35
1-1/2"	48,3*	3,7*	51*	0,5
2"	60,5*	5,5*	76,2*	0,9
2-1/2"	73,2*	7	95,3*	1,79
3"	88,9*	7,6	114,3*	2,74
4"	114,3*	8,6	152,4*	5,36
6"	168,1*	11	228,6*	15

* Reference photos and measurements, subject to change without prior notice from the supplier or manufacturer.