



# TECTUL

## CODO X 45° SCH 40 AC EXTREMOS SOLDABLES

### MATERIALES



### APLICACIONES



### NORMAS DE DISEÑO

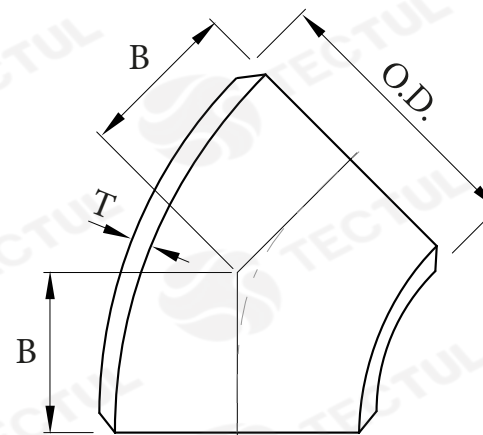

\* Vista de sección transversal de tipo informativa. No representa una versión específica del accesorio o elemento.



### MATERIALES

Accesorio con conexión soldable Butt Weld, fabricados en acero al Carbono A105 y con extremos biselados. Disponibles en Schedule 40 y 80.



### APLICACIONES

Accesorio con conexión soldable Butt Weld. Con extremos biselados. Ideal para la conducción de agua, vapor, gases y aceites



### NORMAS DE DISEÑO

ANSI / ASME B16.9

### DATOS TECNICOS

MEDIDA [in]	DIÁMETRO EXTERIOR OD [mm]	ESPESOR T [mm]	CENTRO AL FINAL B [mm]	PESO [Kg]
1/2"	21,3*	2,8*	15,7*	0,04
3/4"	26,7*	2,9*	19,1*	0,06
1"	33,5*	3,4*	22,4*	0,08
1-1/4"	42,2*	4,6*	25,4*	0,13
1-1/2"	48,3*	3,7*	28,4*	0,19
2"	60,5*	3,9*	35,1*	0,33
2-1/2"	73,2*	5,2	44,5*	0,69
3"	88,9*	5,5	50,8*	1,02
4"	114,3*	6	63,5*	1,92
6"	168,1*	7,1	95,3*	4,97

\* Fotos y medidas referenciales, sujetas a cambios sin previo aviso por parte del proveedor o fabricante.



# TECTUL

## ELBOW X 45° SCH 40 AC BUTT WELD

### MATERIALS



### APPLICATIONS



### DESIGN STANDARDS

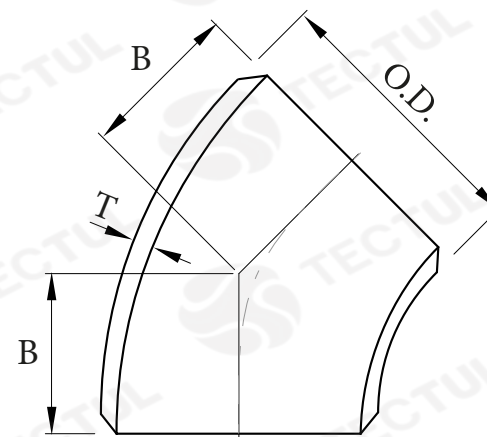

\* Informational cross-sectional view. Does not represent a specific version of the accessory or item.



### MATERIALS

Butt weldable fitting  
Weld, made of carbon steel  
A105 and with beveled ends.  
Available in Schedule 40 and 80.



### APPLICATIONS

Accessory with Butt Weld weldable  
connection. With beveled ends. Ideal for the  
conduction of water, steam, gases and oils



### DESIGN STANDARDS

ANSI / ASME B16.9

### TECHNICAL DATA

MEASURE [in]	EXTERNAL DIAMETER OD [mm]	THICKNESS T [mm]	DISTANCE BETWEEN CENTERS A [mm]	WEIGHT [Kg]
1/2"	21,3*	2,8*	15,7*	0,04
3/4"	26,7*	2,9*	19,1*	0,06
1"	33,5*	3,4*	22,4*	0,08
1-1/4"	42,2*	4,6*	25,4*	0,13
1-1/2"	48,3*	3,7*	28,4*	0,19
2"	60,5*	3,9*	35,1*	0,33
2-1/2"	73,2*	5,2	44,5*	0,69
3"	88,9*	5,5	50,8*	1,02
4"	114,3*	6	63,5*	1,92
6"	168,1*	7,1	95,3*	4,97

\* Reference photos and measurements, subject to change without prior notice from the supplier or manufacturer.