



TECTUL

REDUCCION CONCENTRICA SCH 40 AC EXTREMOS SOLDABLES

MATERIALES



APLICACIONES



NORMAS DE DISEÑO

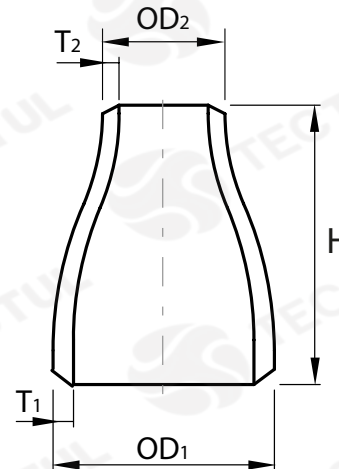

* Vista de sección transversal de tipo informativa. No representa una versión específica del accesorio o elemento.



MATERIALES

Accesorio con conexión soldable Butt Weld, fabricados en acero al Carbono A105. Disponibles en Schedule 40 y 80.



APLICACIONES

Accesorio con conexión soldable Butt Weld. Con extremos biselados. Ideal para la conducción de agua, vapor, gases y aceites



NORMAS DE DISEÑO

ANSI / ASME B16.9

DATOS TÉCNICOS

MEDIDA [in]	DIÁMETRO EXTERIOR (OD1) [mm]	DIÁMETRO EXTERIOR (OD2) [mm]	ESPESOR (T1) [mm]	ESPESOR (T2) [mm]	ALTURA (H)[mm]	Peso [Kg]
3/4" x 1/2"	26,7	21,3	2,87	2,77	38,1	0,06
1" x 3/4"	33,4	26,7	3,38	2,87	50,8	0,12
1" x 1/2"	33,4	21,3	3,38	2,77	50,8	0,11
1-1/4" x 1"	42,2	33,4	3,56	3,38	50,8	0,16
1-1/4" x 3/4"	42,2	26,7	3,56	2,87	50,8	0,15
1-1/4" x 1/2"	42,2	21,3	3,56	2,77	50,8	0,14
1-1/2" x 1-1/4"	48,3	42,2	3,68	3,56	63,5	0,25
1-1/2" x 1"	48,3	33,4	3,68	3,38	63,5	0,22
1-1/2" x 3/4"	48,3	26,7	3,68	2,87	63,5	0,21
2" x 1-1/2"	60,3	48,3	3,91	3,68	76,2	0,38
2" x 1-1/4"	60,3	42,2	3,91	3,56	76,2	0,36
2" x 1"	60,3	33,4	3,91	3,38	76,2	0,33
2-1/2" x 2"	73	60,3	5,16	3,91	88,9	0,73
2-1/2" x 1-1/2"	73	48,3	5,16	3,68	88,9	0,67
2-1/2" x 1-1/4"	73	42,2	5,16	3,56	88,9	0,64
3" x 2-1/2"	88,9	73	5,49	5,16	101,6	0,84
3" x 2"	88,9	60,3	5,49	3,91	101,6	0,85
3" x 1-1/2"	88,9	48,3	5,49	3,68	101,6	0,79
4" x 3"	114,3	88,9	6,02	5,49	101,6	1,45
4" x 2-1/2"	114,3	73	6,02	5,16	101,6	1,37
4" x 2"	114,3	60,3	6,02	3,91	101,6	1,27

* Fotos y medidas referenciales, sujetas a cambios sin previo aviso por parte del proveedor o fabricante.



TECTUL

REDUCER CONCENTRIC SCH 40 AC BUTT WELD

MATERIALS



APPLICATIONS



DESIGN STANDARDS

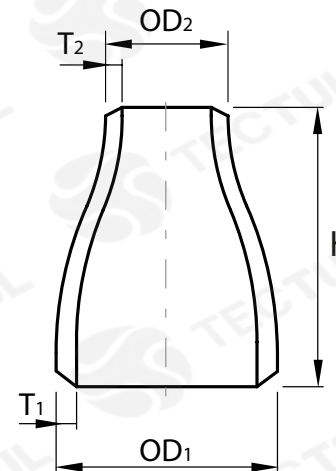

* Informational cross-sectional view. Does not represent a specific version of the accessory or item.



MATERIALS

Butt weldable fitting
Weld, made of carbon steel
A105. Available in Schedule 40 and 80.



APPLICATIONS

Accessory with Butt Weld weldable
connection. With beveled ends. Ideal for the
conduction of water, steam, gases and oils



DESIGN STANDARDS

ANSI / ASME B16.9

TECHNICAL DATA

MEDIDA [in]	EXTERNAL DIAMETER (OD1) [mm]	EXTERNAL DIAMETER (OD2) [mm]	THICKNESS (T1) [mm]	THICKNESS (T2) [mm]	HEIGHT (H)[mm]	WEIGHT [Kg]
3/4" x 1/2"	26,7	21,3	2,87	2,77	38,1	0,06
1" x 3/4"	33,4	26,7	3,38	2,87	50,8	0,12
1" x 1/2"	33,4	21,3	3,38	2,77	50,8	0,11
1-1/4" x 1"	42,2	33,4	3,56	3,38	50,8	0,16
1-1/4" x 3/4"	42,2	26,7	3,56	2,87	50,8	0,15
1-1/4" x 1/2"	42,2	21,3	3,56	2,77	50,8	0,14
1-1/2" x 1-1/4"	48,3	42,2	3,68	3,56	63,5	0,25
1-1/2" x 1"	48,3	33,4	3,68	3,38	63,5	0,22
1-1/2" x 3/4"	48,3	26,7	3,68	2,87	63,5	0,21
2" x 1-1/2"	60,3	48,3	3,91	3,68	76,2	0,38
2" x 1-1/4"	60,3	42,2	3,91	3,56	76,2	0,36
2" x 1"	60,3	33,4	3,91	3,38	76,2	0,33
2-1/2" x 2"	73	60,3	5,16	3,91	88,9	0,73
2-1/2" x 1-1/2"	73	48,3	5,16	3,68	88,9	0,67
2-1/2" x 1-1/4"	73	42,2	5,16	3,56	88,9	0,64
3" x 2-1/2"	88,9	73	5,49	5,16	101,6	0,84
3" x 2"	88,9	60,3	5,49	3,91	101,6	0,85
3" x 1-1/2"	88,9	48,3	5,49	3,68	101,6	0,79
4" x 3"	114,3	88,9	6,02	5,49	101,6	1,45
4" x 2-1/2"	114,3	73	6,02	5,16	101,6	1,37
4" x 2"	114,3	60,3	6,02	3,91	101,6	1,27

* Reference photos and measurements, subject to change without prior notice from the supplier or manufacturer.