



TECTUL

TAPON HEMBRA SCH 80 AC EXTREMOS SOLDABLES

MATERIALES

APLICACIONES

NORMAS DE DISEÑO

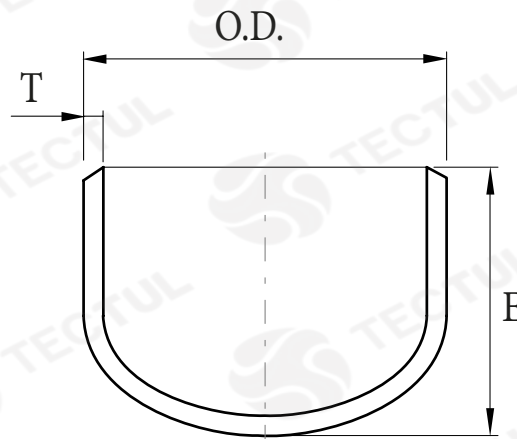

* Vista de sección transversal de tipo informativa. No representa una versión específica del accesorio o elemento.



MATERIALES

Accesorio con conexión soldable Butt Weld, fabricados en acero al Carbono A105 y con extremos biselados. Disponibles en Schedule 40 y 80.



APLICACIONES

Accesorio con conexión soldable Butt Weld. Ideal para la conducción de agua, vapor, gases y aceites



NORMAS DE DISEÑO

ANSI / ASME B16.9

DATOS TÉCNICOS

| MEDIDA [in] | DIÁMETRO EXTERIOR (OD) [mm] | ESPESOR (T) [mm] | LARGO (E) [mm] | PESO [Kg] |
|-------------|-----------------------------|------------------|----------------|-----------|
| 1/2" | 21,3 | 3,7 | 25,4 | 0,04 |
| 3/4" | 26,7 | 3,9 | 25,4 | 0,07 |
| 1" | 33,5 | 4,5 | 38,1 | 0,13 |
| 1-1/4" | 42,2 | 4,9 | 38,1 | 0,21 |
| 1-1/2" | 48,3 | 3,7 | 38,1 | 0,30 |
| 2" | 60,5 | 5,5 | 38,1 | 0,41 |
| 2-1/2" | 73,2 | 7,0 | 38,1 | 0,58 |
| 3" | 88,9 | 7,6 | 50,8 | 0,95 |
| 4" | 114,3 | 9 | 63,5 | 1,58 |
| 6" | 168,1 | 11,0 | 88,9 | 4,21 |

* Fotos y medidas referenciales, sujetas a cambios sin previo aviso por parte del proveedor o fabricante.



TECTUL

CAP SCH 80 AC BUTT WELD

MATERIALS



APPLICATIONS



DESIGN STANDARDS

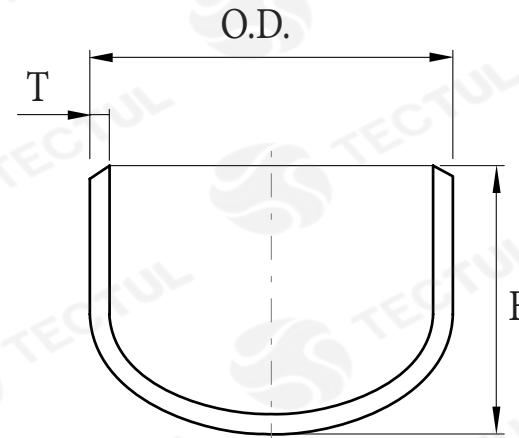

* Informational cross-sectional view. Does not represent a specific version of the accessory or item.



MATERIALS

Butt weldable fitting
Weld, made of carbon steel
A105 and with beveled ends.
Available in Schedule 40 and 80.



APPLICATIONS

Accessory with Butt Weld weldable
connection. Ideal for the
conduction of water, steam, gases and oils



DESIGN STANDARDS

ANSI / ASME B16.9

| TECHNICAL DATA | | | | |
|----------------|-----------------------------|--------------------|-----------------|-------------|
| MEASURE [in] | EXTERNAL DIAMETER (OD) [mm] | THICKNESS (T) [mm] | LENGTH (E) [mm] | WEIGHT [Kg] |
| 1/2" | 21,3 | 3,7 | 25,4 | 0,04 |
| 3/4" | 26,7 | 3,9 | 25,4 | 0,07 |
| 1" | 33,5 | 4,5 | 38,1 | 0,13 |
| 1-1/4" | 42,2 | 4,9 | 38,1 | 0,21 |
| 1-1/2" | 48,3 | 3,7 | 38,1 | 0,30 |
| 2" | 60,5 | 5,5 | 38,1 | 0,41 |
| 2-1/2" | 73,2 | 7,0 | 38,1 | 0,58 |
| 3" | 88,9 | 7,6 | 50,8 | 0,95 |
| 4" | 114,3 | 9 | 63,5 | 1,58 |
| 6" | 168,1 | 11,0 | 88,9 | 4,21 |

* Reference photos and measurements, subject to change without prior notice from the supplier or manufacturer.