



TECTUL

TAPA COBRE

MATERIALES

CARACTERÍSTICAS FÍSICAS



CARACTERÍSTICAS DIMENSIONALES

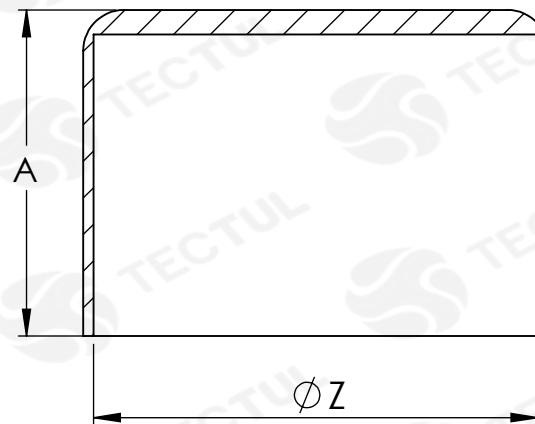

* Vista de sección transversal de tipo informativa. No representa una versión específica del accesorio de cobre.

MATERIALES



Están diseñados para sistemas de agua potable, calefacción, aire acondicionado, gases medicinales y energía solar térmica.

CARACTERÍSTICAS FÍSICAS



Los accesorios fundidos son ofrecidos en aleaciones de cobre. Cumple con los estándares de diseño ASME/ANSI B16.22 y ASME/ANSI B16.18

CARACTERÍSTICAS DIMENSIONALES



Son fabricados de acuerdo a las especificaciones B584 de ASTM, ASTM B75 de aleación C12200

DATOS TÉCNICOS

MEDIDA	LONGITUD [mm] (A)	DIAMETRO INTERNO [mm](Z)	PESO [g]
1/2"	15,90*	14,40*	9,07*
3/4"	21,00*	20,60*	22,67*
1"	26,40*	26,79*	31,75*

* Fotos y medidas referenciales, sujetas a cambios sin previo aviso por parte del proveedor o fabricante.



TECTUL

COPPER CAP

MATERIALS

PHYSICAL CHARACTERISTICS

DIMENSIONAL CHARACTERISTICS

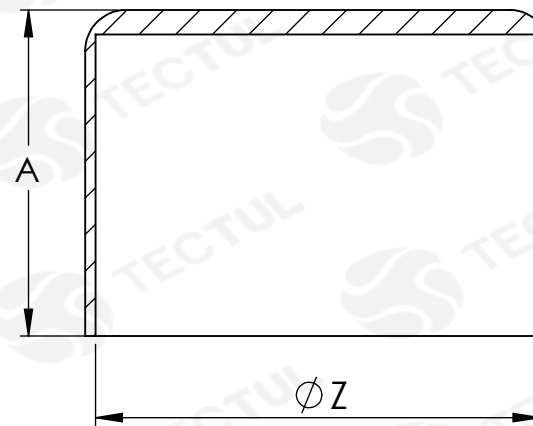

* Informational type cross section view. It does not represent a specific version of the copper fitting.

MATERIALS

They are designed for water drinking systems, heating, air-conditioning, medicinal gases and thermal solar energy.

PHYSICAL CHARACTERISTICS

Cast fittings are offered in copper alloys. Meets the ASME / ANSI B16.22 design standards and ASME / ANSI B16.18.

DIMENSIONAL CHARACTERISTICS

They are manufactured under the standards NTC 382, NTC 1339 and NTC 576.

TECHNICAL DATA

MEASURE	LENGTH [mm] (A)	INTERNAL DIAMETER [mm](Z)	WEIGHT [g]
1/2"	15,90*	14,40*	9,07*
3/4"	21,00*	20,60*	22,67*
1"	26,40*	26,79*	31,75*

* Reference photos and measurements, subject to change without prior notice from the supplier or manufacturer.