



# TECTUL

# HEMBRA ALUMINIO

## MATERIALES

### CARACTERÍSTICAS FÍSICAS



### CARACTERÍSTICAS DIMENSIONALES



## DATOS TÉCNICOS

MEDIDA ROSCA [in] (R1)	ANCHO [mm] (A)	DIÁMETRO MANGUERA [mm] (B)	DIÁMETRO INTERNO 1 [mm] (C1)	INSERCIÓN MANGUERA [mm] (D)	ALTURA [mm] (E)	PESO (g)
1 1/2"	58,00*	39,00*	30,80*	70,00*	102,00*	175*
2"	70,00*	49,80*	42,00*	71,00*	103,00*	245*
3"	95,00*	75,00*	63,80*	106,00*	145,50*	586*
4"	127,00*	102,70*	86,70*	115,00*	157,40*	1002*

\* Fotos y medidas referenciales, sujetas a cambios sin previo aviso por parte del proveedor o fabricante.

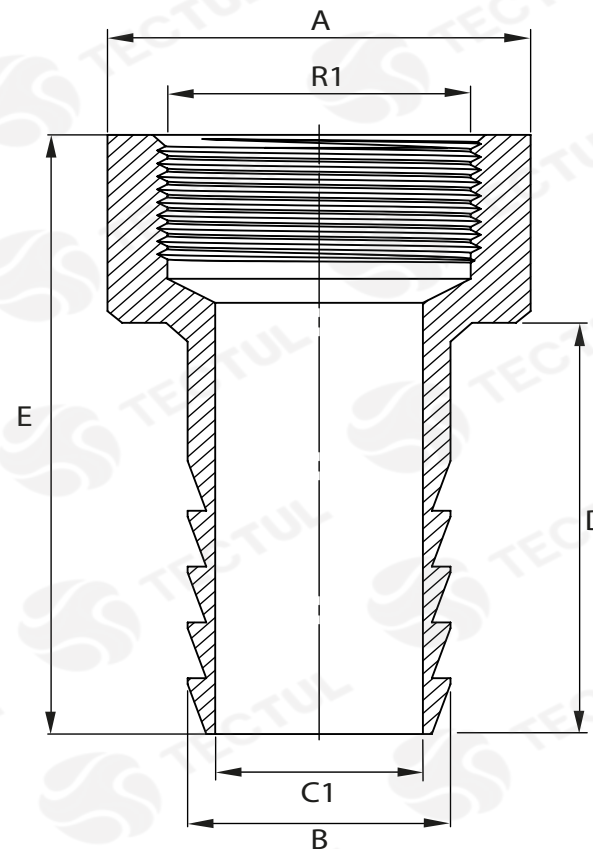

## DATOS TÉCNICOS

ATRIBUTO	DESCRIPCIÓN
Tipo de Pieza	Hembra
Cuerpo	Aluminio
Rango Máximo de Presión	1/2" - 4" 150 PSI / 5" - 6" 75 PSI / 8" PSI
Temperatura	Ambiente
Características	Aleación de aluminio, diseñada especialmente para alta resistencia a la tensión, ligereza y rigidez.
Tipo de Rosca	NPT (Cónica - Rosca Tubería Nacional)
Conexión	Adaptador Manguera - Rosca NPT Hembra

\* Fotos y medidas referenciales, sujetas a cambios sin previo aviso por parte del proveedor o fabricante.

Última Revisión: Diciembre 2021



# TECTUL

# ALUMINUM FEMALE

## MATERIALS

## PHYSICAL CHARACTERISTICS



## DIMENSIONAL CHARACTERISTICS



## TECNICAL DATA

THREAD SIZE [In] (R1)	WIDTH [mm] (A)	HOSE DIAMETER [mm] (B)	INTERNAL DIAMETER 1 [mm] (C1)	HOSE INSERTION [mm] (D)	HEIGHT [mm] (E)	WEIGHT (g)
1 1/2"	58,00*	39,00*	30,80*	70,00*	102,00*	175*
2"	70,00*	49,80*	42,00*	71,00*	103,00*	245*
3"	95,00*	75,00*	63,80*	106,00*	145,50*	586*
4"	127,00*	102,70*	86,70*	115,00*	157,40*	1002*

\* Reference photos and measurements, subject to change without prior notice from the supplier or manufacturer.

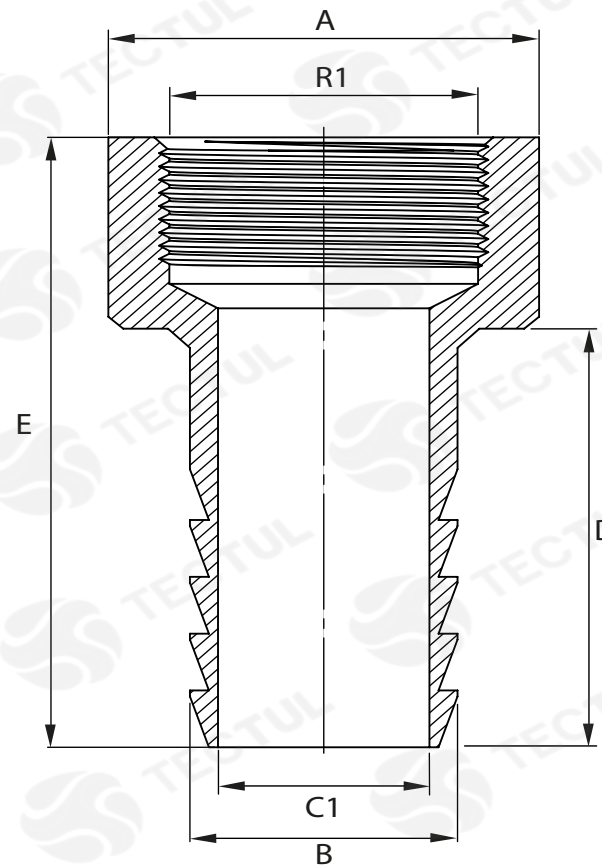

## TECNICAL DATA

ATTRIBUTE	DESCRIPTION
Type of Piece	Female
Body	Aluminum
Maximun Pressure Range	1/2" - 4" 150 PSI / 5" - 6" 75 PSI
Temperature	Environment
Features	Aluminum alloy, specially designed for high tensile strength, lightness and rigidity.
Thread Type	NPT (Conical - National Pipe Thread)
Connection	Hose Adapter - Female NPT Thread

\* Reference photos and measurements, subject to change without prior notice from the supplier or manufacturer.