



TECTUL

TUBO HIERRO GALVANIZADO PESADO

MATERIALES

CARACTERÍSTICAS FÍSICAS

CARACTERÍSTICAS DIMENSIONALES

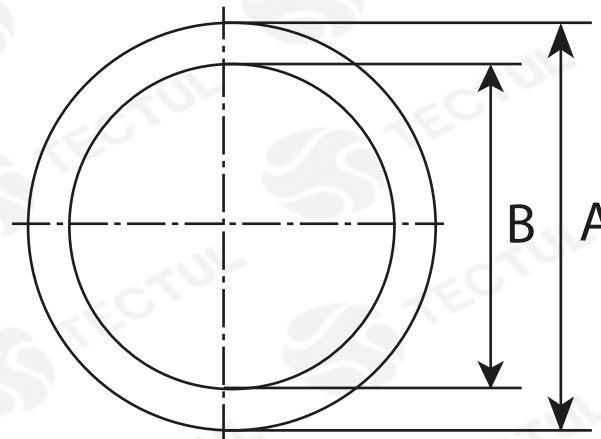
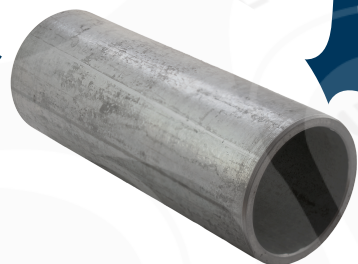

* Vista de sección transversal de tipo informativa. No representa una versión específica del accesorio o elemento.



MATERIALES

Tubería fabricada en acero galvanizado laminado en caliente. Con Costura ERW. Schedule 40



CARACTERÍSTICAS FÍSICAS

Para conducción de fluidos y aplicaciones como gas natural, GLP, agua fría y caliente, vapor, sistemas de protección contra incendios y sistemas de riego



CARACTERÍSTICAS DIMENSIONALES

La tubería cumple la calidad ASTM A-53, mediante los lineamientos ISO 9001:2008. Extremos Roscados NPT ASME B1.20.1

DATOS TÉCNICOS

DIÁMETRO NOMINAL	DIÁMETRO EXTERNO [mm] [A]	ESPESOR PARED [mm]	DIÁMETRO INTERNO [mm] [B]	PESO [Kg/m]
1/2"	21,30*	2,77*	15,76*	1,26*
3/4"	226,70*	2,87*	20,96*	1,67*
1"	33,40*	3,38*	26,64*	2,50*
1-1/4"	42,20*	3,56*	35,08*	3,38*
1-1/2"	48,30*	3,68*	40,94*	4,03*
2"	60,30*	3,91*	52,94*	5,43*
3"	88,90*	5,49*	77,92*	11,28*
4"	114,30*	6,02*	102,26*	16,07*

* Fotos y medidas referenciales, sujetas a cambios sin previo aviso por parte del proveedor o fabricante.



TECTUL

HEAVY GALVANIZED IRON PIPE

MATERIALS



PHYSICAL CHARACTERISTICS



DIMENSIONAL CHARACTERISTICS

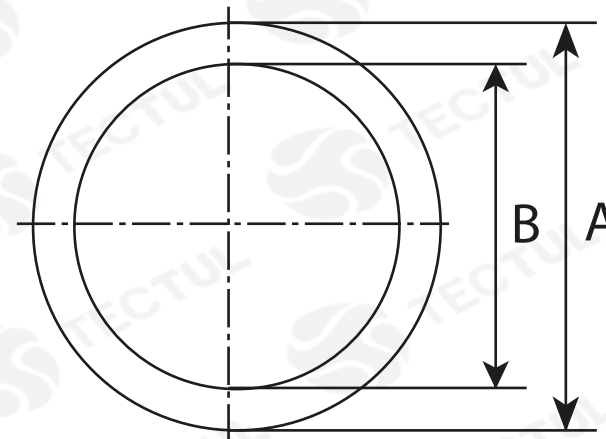
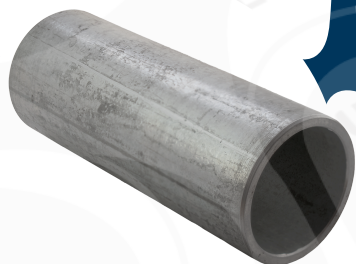

* Informational cross-sectional view. Does not represent a specific version of the accessory or item.

MATERIALS

Pipe made of galvanized steel hot rolled. With ERW Seam. Schedule 40

PHYSICAL CHARACTERISTICS

For fluid handling and applications such as natural gas, LPG, hot and cold water, steam protection systems firefighting and irrigation systems

DIMENSIONAL CHARACTERISTICS

The pipe meets the quality ASTM A-53, through the ISO 9001:2008 guidelines. Threaded Ends NPT ASME B1.20.1

TECHNICAL DATA				
NOMINAL DIAMETER	EXTERNAL DIAMETER [mm] [A]	WALL THICKNESS [mm]	INTERNAL DIAMETER [mm] [B]	WEIGHT [Kg/m]
1/2"	21,30*	2,77*	15,76*	1,26*
3/4"	226,70*	2,87*	20,96*	1,67*
1"	33,40*	3,38*	26,64*	2,50*
1-1/4"	42,20*	3,56*	35,08*	3,38*
1-1/2"	48,30*	3,68*	40,94*	4,03*
2"	60,30*	3,91*	52,94*	5,43*
3"	88,90*	5,49*	77,92*	11,28*
4"	114,30*	6,02*	102,26*	16,07*

* Reference photos and measurements, subject to change without prior notice from the supplier or manufacturer.